

PUSH SWITCH

SPECIFICATION

Contact Rating : 10A 250V AC TV-8

Contact Resistance : 100 mΩ MAX

Insulation Resistance : 500 MΩ (MIN) 500V DC

Dielectric Strength : 2000V AC-1 minute

Electric Life : 25,000 cycles

Operating Force : 500 ± 200gram

PART NO : PS3-22SPA



PART NUMBERING SYSTEM

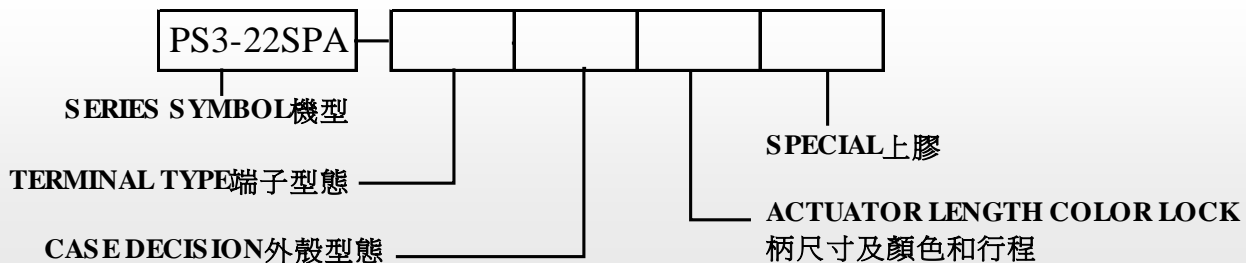

DIMENSIONS

in mm

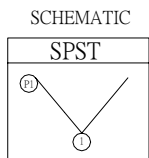
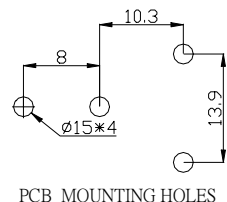
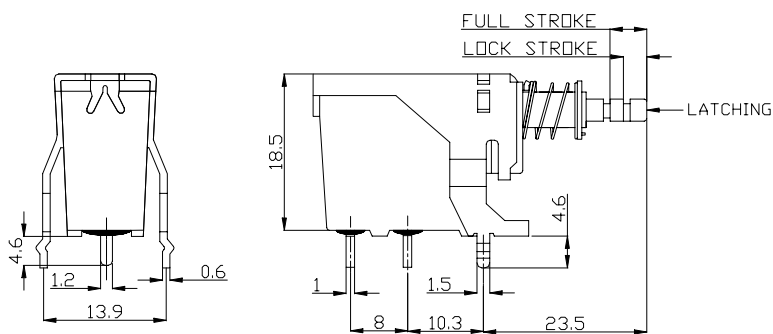

LOCK STROKE	FULL STROKE
1.5mm	2.5mm
2.5mm	3.5mm

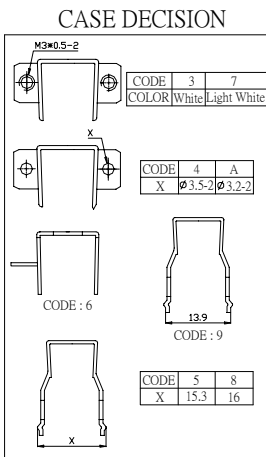
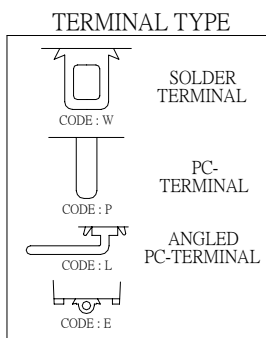

ACTUATOR LENGTH COLOR LOCK 柄尺寸及顏色和行程

	CODE	COLOR LOCK
18mm	C	BABY BLUE 藍色 2.5mm
	J	ORANGE 橘黃色 2.5mm
	D	GREY 灰色 1.5mm
16mm	E	BLUE 藍色 2.5mm
17.4mm	F	WHITE 白色 2.5mm
17.6mm	B	WHITE 白色 2.5mm
	Q	ORANGE 橘黃色 2.5mm
20mm	R	RED 紅色 2.5mm
	H	GREY 灰色 2.5mm
14.7mm	L	BLUE 藍色 2.5mm
	Y	YELLOW 黃色 2.5mm